

HAKA 89/45W

Technical data

	operation when directly connected to chimney	
	HAKA 89/45W	HAKA 89/45W+
Energy label	A+	A+
Operating data		
Nominal heat power / Power absorbed to water	14 / 10,2 kW	22 / 15,1 kW
Efficiency	> 80 %	> 80 %
Consumption of wood	3,7 kg/h	6 kg/h
Mass flow of flue gas	10,6 g/s	17 g/s
Required chimney pressure	12 Pa	12 Pa
Required amount of combustion air	35 m ³ /h	55 m ³ /h
Average flue gas temperature		
on the output	214 °C	240 °C
Heat distribution		
fireplace insert	9 %	11 %
door glass (single / double)	0 / 19 %	0 / 21 %
water	72 %	68 %
Water exchanger specifications		
Maximum working pressure	2,5 bar	2,5 bar
Minimum return water temperature	60 °C	60 °C
Water capacity	56 liters	56 liters
Connection input / output	1" / 1"	1" / 1"
Information for builds		
Minimal grill area supply / outgoing (with vent. grill)	300 / 350 cm ²	500 / 600 cm ²
Minimum radiant area ³ (without vent. grill)	suitable	suitable
Minimum distance from insulated areas / floor	20 / 0 mm	40 / 0 mm
Reference insulation ¹ ceiling / back wall / side wall / floor	100 / 60 / 60 / 0 mm	100 / 60 / 60 / 0 mm
Calciumsilicate insulation ² ceiling / back wall / side wall / floor	75 / 45 / 45 / 0 mm	75 / 45 / 45 / 0 mm
General technical information		
Total weight / lining weight	circa 435 / 120 kg	circa 435 / 120 kg
Burning chamber dimensions (width x depth)	810 x 315 mm	
Combustion air connection	Ø 125 mm	Ø 150 mm
Use in non-ventilated accumulation builds according to craft rules	suitable ⁴	
Tested according to	EN 13229	
Meets values	1. BlmSchV (Stufe2), 15a BVG	

Nr.	Thread size	Description
1	G 1" (AG)	Water supply from heating system - min. 60 °C
2	G 1" (AG)	Hot water supply to heating system
3	G 1/2" (AG)	Water supply from the waterlines into the cooling loop
4	G 1/2" (AG)	Discharge of water from the cooling loop into the waste
5	G 3/8" (IG)	Pocket for air vent valve
6	G 1/2" (IG)	Pocket for thermal sensors
7	G 1/2" (IG)	Pocket for emptying

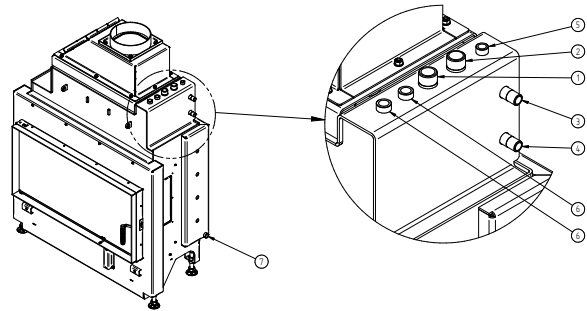

1 Mineral wool according to AGI-Q 132

2 Example SkamoEnclosure Board 225 kg/m³

3 Depends on accumulation period and material characteristics. Listed values calculated with average specific heat output = approx. 500 W/m²

4 With regard to the inspection capability and maximum ambient temperatures of the external switching devices (e.g. TAS/SV)

HAKA 89/45W

HAKA 89/45W, HAKA 89/45W extra power+ / air inlet / feet

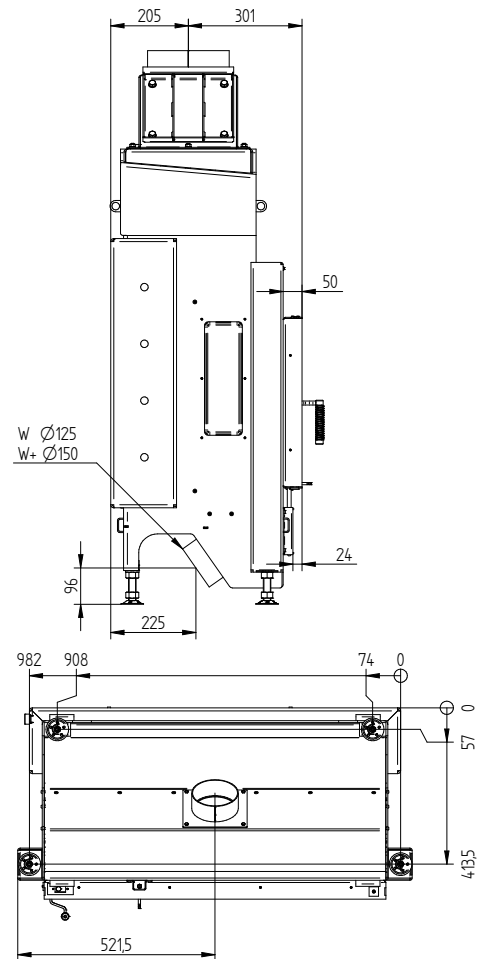
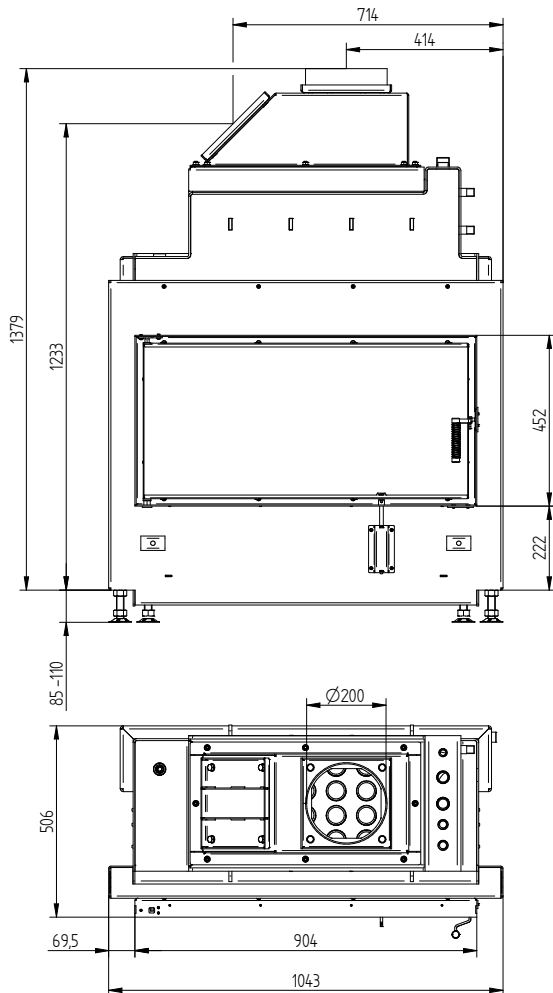

HAKA 89/45W

Cover frame 89/45 side opening 4sides 50 mm 1 x 90°

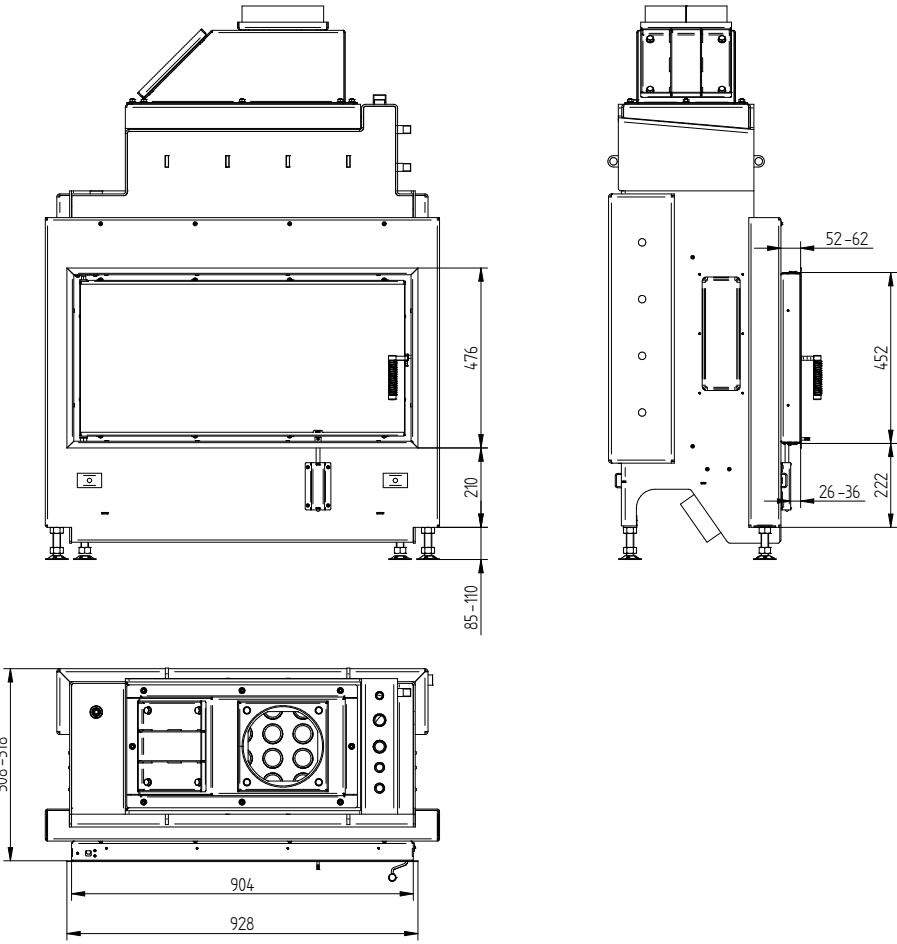

HAKA 89/45W

Cover frame 89/45 side opening 4sides 80 mm 1 x 90°

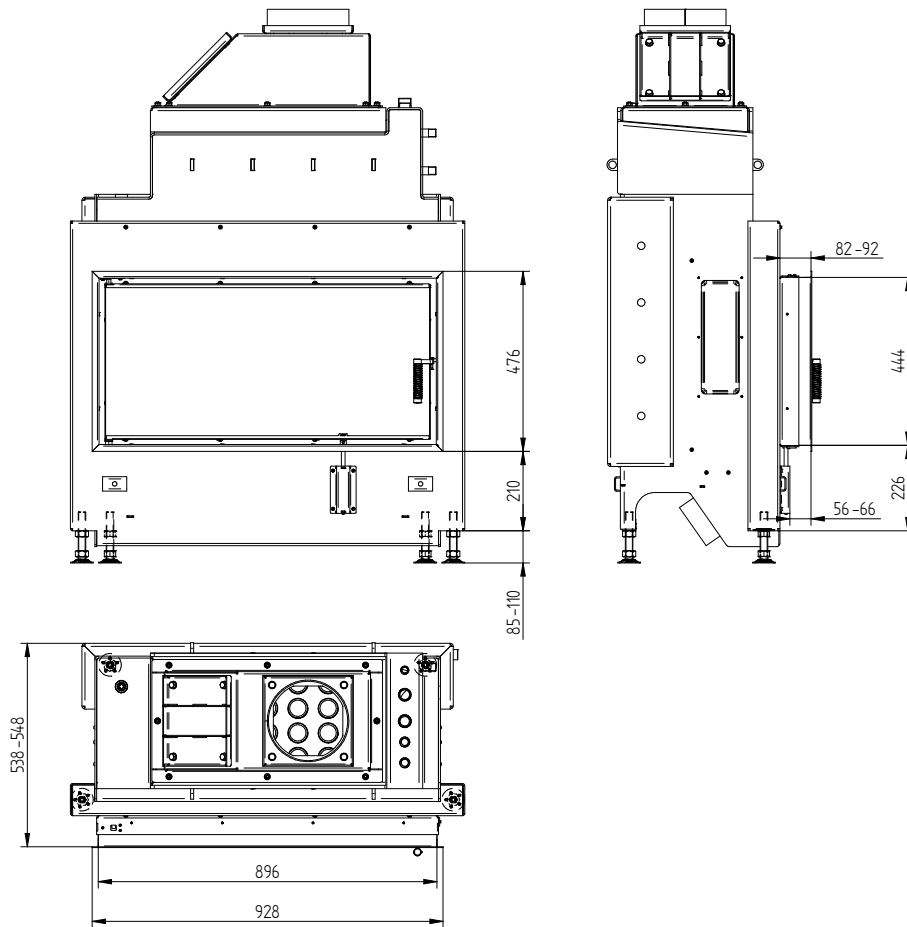

HAKA 89/45W

Build-on frame 89/45 side opening 4sides 80 mm

