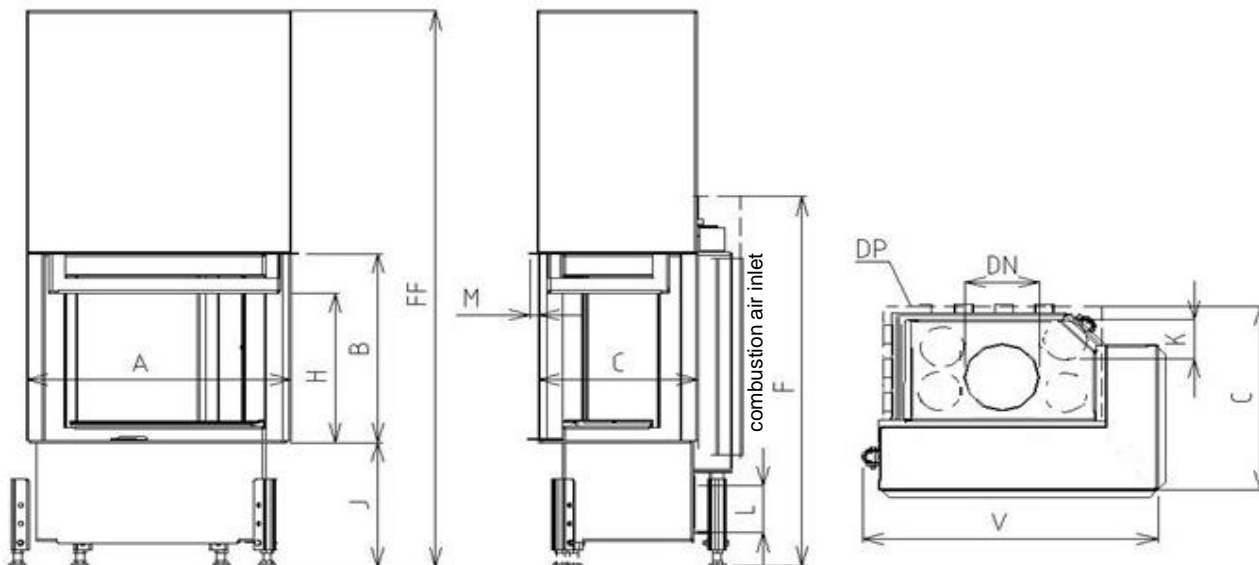

KAZETA R90 67 VD 720/450,510-S/380 (L/P)

Low-energy range 67

Low-energy fireplace insert

	Sizes		KAZETA R90	KAZETA R90
			67 VD 720/450-S/380 (L/P)	67 VD 720/510-S/380 (L/P)
1	A	mm	720	
2	F	mm	1060	1120
3	C	mm	480	
4	DN	Ø mm	180	
5	B	mm	450	510
6	FF	mm	1350	1470
7	R	mm	380	
8	V	mm	775	
9	H	mm	315	375
10	J	mm	325 + /160/	
11	K	Ø mm	4x125	
12	L	Ø mm	125	
13	M	mm	20	
14	N	mm		

Basic design:

Thermodynamic Hearth
 Segment chamotte lining
 Glass Classic
 Inox control grip-handle MP2
 Enviromentally friendly varnish

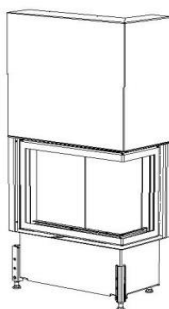

KAZETA R90-S/380 P VD

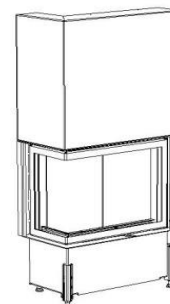

KAZETA R90-S/380 L VD

Technical parameters			
1	Nominal heat output	kW	6,5
2	Pressure required	Pa	12
3	Average efficiency	%	77,7
4	Average flue gas temperature	°C	259
5	Wood consupcion	kg/h	2,1
6	Consumption of combustion air	m ³ /hod	19,5
7	Emission of CO to 13% O2	%	0,1
8	Flue gas mass flow	g/s	6,8
9	Weight	kg	250
10	Required min. cross section for circulating air - INPUT	cm ²	200
11	Required min. cross section for circulating air - OUTPUT	cm ²	325
12	Three-component insulated chimney - active height 5 m	Ø cm	180
13	Character of building construction with fireplace insert	warm air convection	Yes
		heat storage without conv	No

Optional accessories:

Cover frame (KR)
 Glass Reflex (SR)
 Black printed glass(SM)
 Black printed glass Reflex (SMR)
 External ashtray (VOP)
 Lower hearth (ZO)
 Rear feeding door (PD)
 Vertical heat-storing panel (AZ)

Test Method: ČSN EN 1322/A2:2007, FprEN16510-1, FprEN16510-2-2

Fireplace complies with the requirements: EN 13229, DIN +, BlmSchV-Stufe 2, Commission Regulation (EU) č. 2015/1185 Ecodesign requirements

KOBOK reserves the right to change dimensions and parameters described in these sheets. The current edition can be downloaded from www.KOBOK.sk