

BELLEVILLE 700C / BELLEVILLE 700CL

Everything has been thought of in the BELLEVILLE wood burner so that you can fully enjoy the spectacle of the fire from the living room. Its cubic design brings elegance and a chic air to your home. In addition, its integrated woodshed allows you to have firewood at your fingertips.



BELLEVILLE 700C
FR9011010B
EAN: 3760075412005



BELLEVILLE 700CL
FR9011002B
EAN: 3760075412012



> SPECIFICATIONS

PRODUCT INFORMATION		
Model	BELLEVILLE 700C	BELLEVILLE 700CL
Log size (cm)	50 (55 max)	
Warranty*	5 years	
Dimensions LxHxD (cm)	67 x 92 x 51	100 x 92 x 51
Gross weight (kg)	191	197
Net weight (kg)	164	166
PRODUCT PERFORMANCE		
Nominal Power (kW)	7.9	
Power range (kW)	5 to 14	
Efficiency (%)	75	
Seasonal efficiency (%)	65	
CO2 emission (13% O2) (%/mg/Nm³)	0.09 - 1125	
Dual combustion	Yes	
Ecodesing	Yes	
Airtight	Yes	
INSTALLATION AND SIZING		
Ø combustion gas outlet nozzle (mm)	150	
Flue gas connection	above	
Flue collar	Male	
Ø Combustion air inlet nozzle	75 mm (bottom and back)	
Mean flue gas temperature	278 °C	
Flue gas mass flow (g/s)	10	
Nozzle depression for sizing	12 Pa	
CO ₂ emission (%)	8.14	
Back installation distance (cm)	30	
Lateral installation distance (cm)	30	

*2 years for parts and 5 years for heating elements

> INSTALLATION

- Plinth drawer (standard) for storing accessories or firewood (67 cm long woodshed for BELLEVILLE 700C)
- 1 metre wide XXL woodshed (BELLEVILLE 700CL)
- 4 adjustable feet ensure perfect levelling of the appliance.

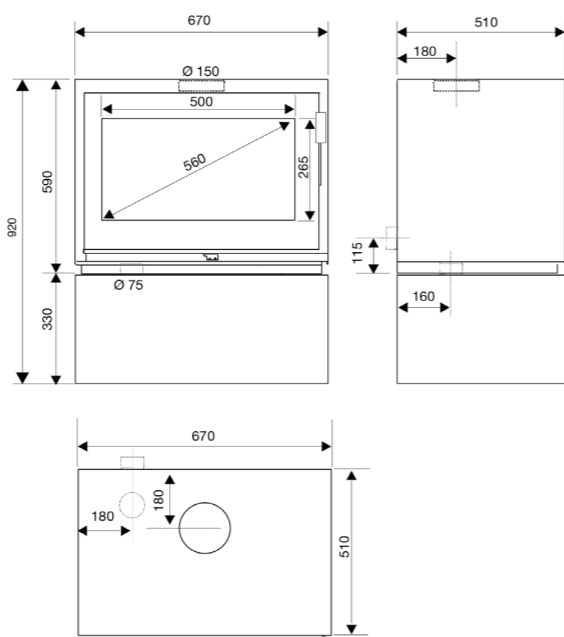

BELLEVILLE 700C



- > MATERIALS
- Thick steel firebox
 - Vermiculite interior protected with cast-iron plates
 - Cast-iron floor sill and grating (3 pcs)

Integrated woodshed for storing firewood within easy

> AESTHETICS

- Front opening door
- Cubic design
- Thick-walled steel black coating (front and back)
- Chic and elegant appearance

> COMBUSTION

State-of-the-art heating body for more efficient and cleaner combustion (minimum CO and dust content) thanks to essential factors:

- Its airtightness for perfect combustion air control (primary air, secondary air and window air fully channelled and controllable)
- Its 2 vermiculite-coated steel and stainless steel baffles (removable without tools)
- A secondary air ramp for efficient dual combustion

Natural heat transfer to the front of the appliance for optimum comfort.

> USE

- Easily accessible ashtray that allows easy maintenance
- Individual air control for combustion control
- "Clean glass" System

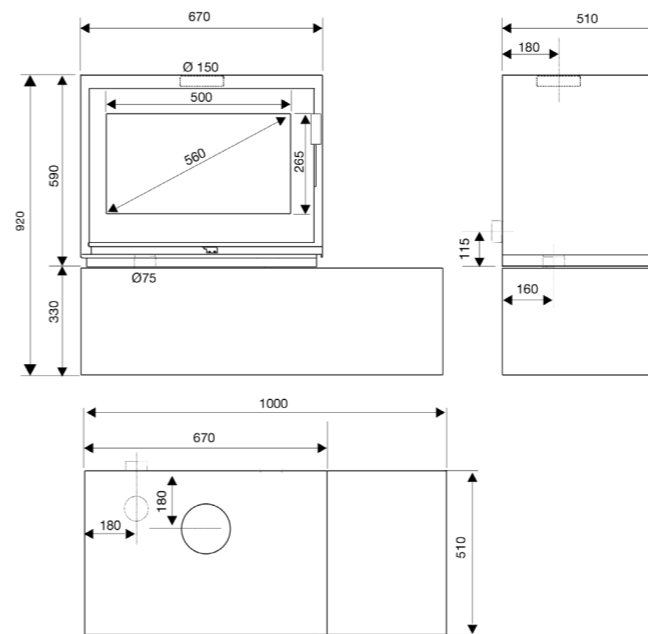

BELLEVILLE 700CL